

INOX IHP

ABOUT USING WATER



CV

HP Check Valve



General features

- High reliability for heavy and continuous duties
- Metal-to-metal seal
- Construction: in-line gas threaded (LFG version), in-line cartridge (CST version), in-line interflanged, 90° cartridge (CFE version)

Options

- ANSI or CETOP flanges kit
- Calibrated spring up to 4 bar or no spring version
- VHP version (up to 2000 bar)

Applications

- Designed to be used in steel working and metallurgical industries

Technical data

Fluid: Water and HFA
Working pressure: 31,5 Mpa - 75 Mpa
Ambient temperature: +2°C ÷ +60°C
Calibrated spring: 0,05 MPa
Materials: Stainless steel

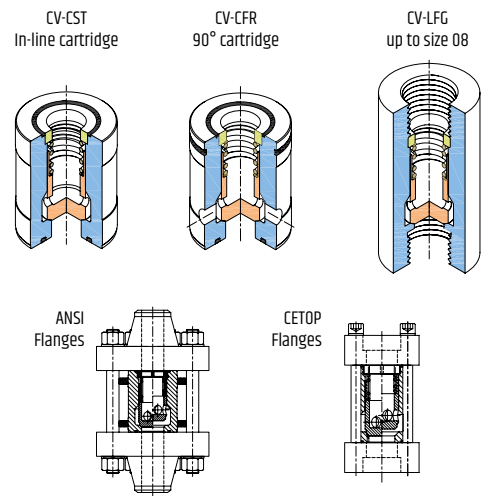

Selection diagram

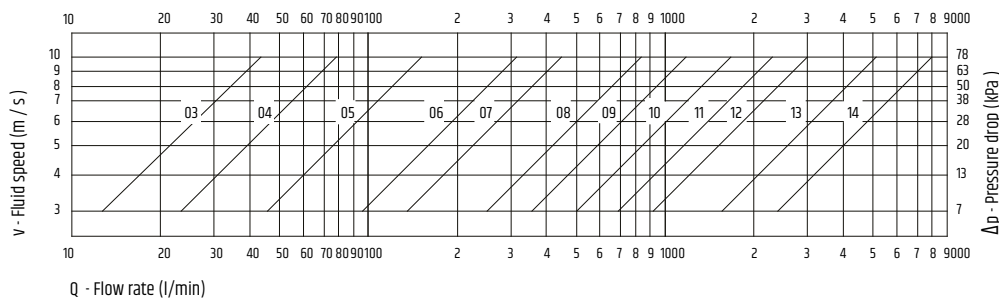

Valves sizes

INOXHP	ND	inches	PN
03	15	1/2"	750
04	20	3/4"	750
05	25	1"	500
06	32	1 1/4"	500
07	40	1 1/2"	400
08	50	2"	400
09	65	2 1/2"	350
10	80	3"	350
11	100	4"	350
12	125	5"	350
13	150	6"	315
14	200	8"	315

1 bar = 14.5psi

This valve model is EAC certified



INOXHP S.r.l.
 IT - 20834 Nova Milanese (MB) - Via Garibaldi, 89 - Tel: +39 0362 190111
 Fax: +39 0362 1901008 - E-mail: inoxihp@inoxihp.com - inoxihp.com

ABOUT USING WATER