

INOXIHP
ABOUT USING WATER

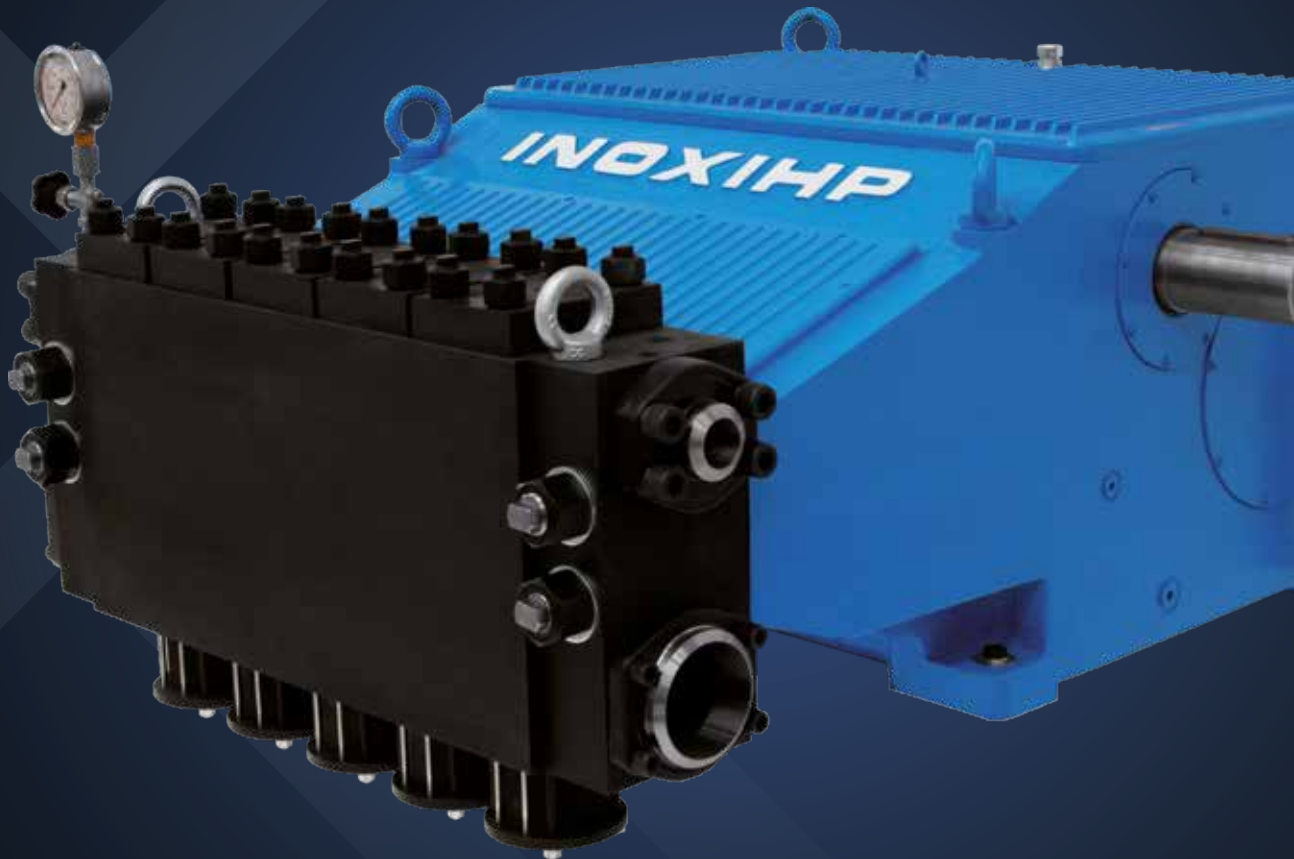

PF 550

Reciprocating Horizontal
Quintuplex Plunger Pumps



PF 550



General features

- Compact dimension
- Low noise
- Forced lubrication system
- Easy maintenance
- Low maintenance costs
- Internal double reduction gears with helical gears
- Input shaft can be placed on either side of the pump
- Self-adjusting seal packing
- pumping package cooling system
- Available with carbon steel or stainless steel hydraulic head
- Low vibrations
- Constant hydraulic flow with minimal pulsation: no pulsation dampener required

Accessories

- Valve lifter controlled by means of pneumatic solenoid
- Regulating pressure valve
- Unloading valve
- Pressure-relief valve
- HP check valve
- Suction and/or delivery gauge
- Low and high pressure switches
- Simplex or duplex suction filter
- Manifold groups for suction/delivery

Applications

- Descaling system
- Hydrostatic bearing lubrication
- Press drive
- Hydraulic testing
- Coal mining
- Industrial cleaning
- Spunlace
- Deburring

Pulsation diagram

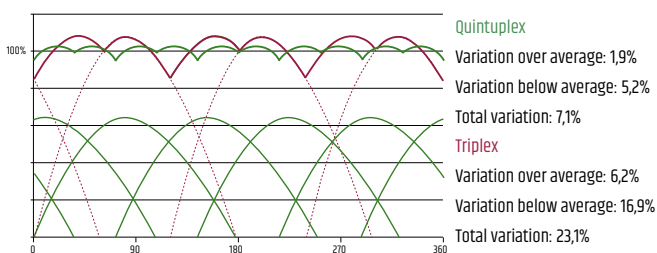

Identification code

see tables on the next page >>>

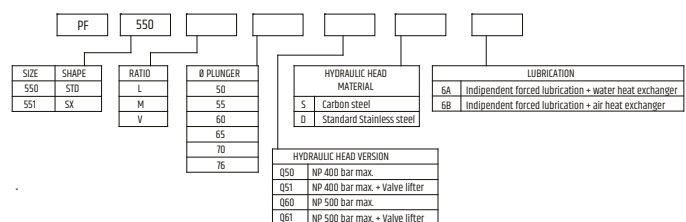

Dimensions

Dimensions are referred to hydraulic head Q50
 Weight: kg 3066

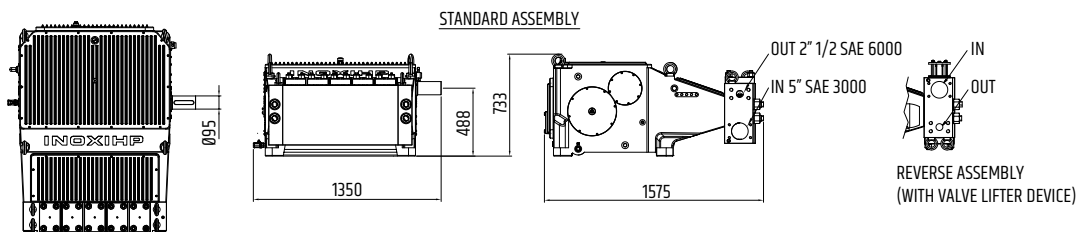

Pumping Group

PF 550



Composed of

- Pump PF 550 with forced lubrication complete with pressure, temperature and oil level switches
- Electric motor
- Safety valve
- Coupling with cover
- Delivery Pressure gauge
- Frame
- Suction pressure switch
- Flanges

Options

- Manifold groups for suction/delivery
- Junction box
- Suction filters simplex or duplex with/without clogging detection sensor
- Valve lifter controlled by means of pneumatic solenoid
- HP check valve
- Low and high pressure switches
- Simplex or duplex suction filter

Dimensions

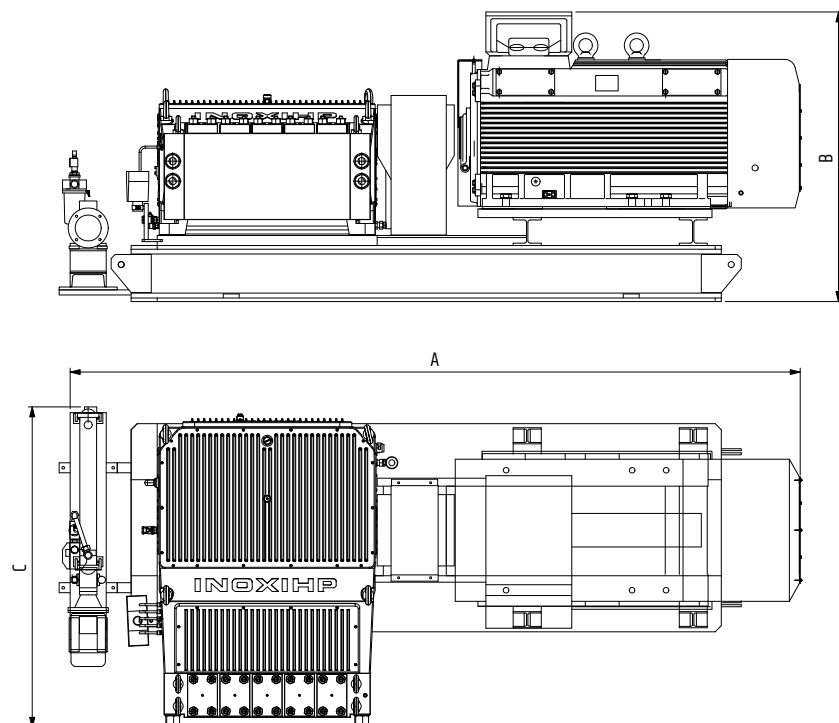

POWER (kW)	DIMENSIONS (mm)			WEIGHT (kg)
	A	B	C	
315	3665	1450	1545	6745
355	3665	1450	1545	6795
400	4180	1450	1545	7800
450	4180	1450	1545	7850
500	4180	1450	1545	8060
560	4180	1450	1545	8160



These pump and pumping group model are EAC certified



INOXIHP S.r.l.

IT - 20834 Nova Milanese (MB) - Via Garibaldi, 89 - Tel: +39 0362 190111
Fax: +39 0362 1901008 - E-mail: inoxihp@inoxihp.com - inoxihp.com

INOXIHP
ABOUT USING WATER