

INOXIHP
ABOUT USING WATER



PF 190

Reciprocating Horizontal
Triplex Plunger Pumps



PF 190



General features

- Compact dimension
- Lubrication system with oil filtration circuit + heat exchanger
- Easy maintenance
- Low maintenance costs
- Internal reduction gear
- Self-adjusting seal packing
- Available with carbon steel or stainless steel hydraulic head

Accessories

- Valve lifter controlled by means of pneumatic solenoid
- Regulating pressure valve
- Unloading valve
- Pressure-relief valve
- HP check valve
- Suction and/or delivery gauge
- Low and high pressure switches
- Simplex or duplex suction filter
- Manifold groups for suction/delivery

Applications

- Descaling system
- Disk saw cooling
- Hydrostatic bearing lubrication
- Press drive
- Hydraulic testing
- Coal mining
- Industrial cleaning
- Spunlace
- Deburring

Identification code

see tables on the next page >>>

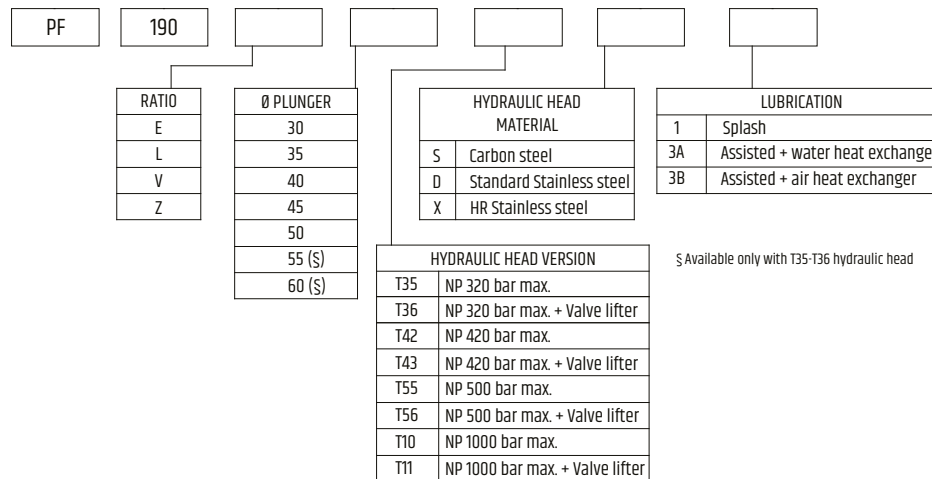

Dimensions

Dimensions are referred to hydraulic head T35
Weight: kg 660

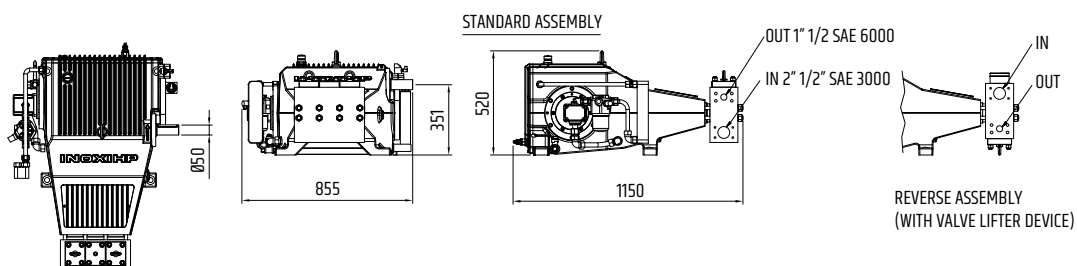

Pumping Group

PF 190



Composed of

- Pump PF 190 with splash or assisted lubrication complete with delivery pressure gauge and flanges
- Electric motor
- Safety valve
- Coupling with cover
- Frame
- Suction pressure switch

Options

- Manifold groups for suction/delivery
- Junction box
- Suction filters simplex or duplex with/without clogging detection sensor
- Valve lifter controlled by means of pneumatic solenoid
- HP check valve
- Low and high pressure switches
- Simplex or duplex suction filter

Dimensions

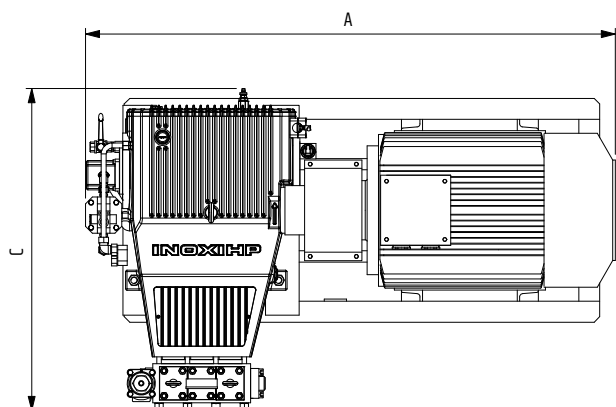
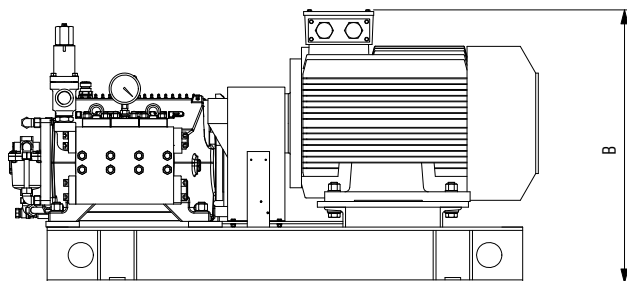

POWER (kW)	DIMENSIONS (mm)			WEIGHT (kg)
	A	B	C	
37	1655	936	1150	1125
45	1685	936	1150	1160
55	1750	936	1150	1230
75	1845	971	1150	1420
90	1875	971	1150	1550
110	2110	1101	1150	1910
132	2140	1101	1150	2000
160	2140	1101	1150	2060



These pump and pumping group model are EAC certified



INOXIHP S.r.l.

IT - 20834 Nova Milanese (MB) - Via Garibaldi, 89 - Tel: +39 0362 190111
Fax: +39 0362 1901008 - E-mail: inoxihp@inoxihp.com - inoxihp.com

INOXIHP
ABOUT USING WATER