

INOXIHP
ABOUT USING WATER



PF 140

Reciprocating Horizontal
Triplex Plunger Pumps



PF 140



General features

- Compact dimension
- Splash lubrication and oil level switch
- Easy maintenance
- Low maintenance costs
- Internal reduction gear
- Self-adjusting seal packing
- Available with carbon steel or stainless steel hydraulic head

Accessories

- Valve lifter controlled by means of pneumatic solenoid
- Regulating pressure valve
- Unloading valve
- Pressure-relief valve
- HP check valve
- Suction and/or delivery gauge
- Low and high pressure switches
- Lubrication system with oil filtration circuit + heat exchanger
- Simplex or duplex suction filter
- Manifold groups for suction/delivery

Applications

- Descaling system
- Disk saw cooling
- Hydrostatic bearing lubrication
- Press drive
- Hydraulic testing
- Coal mining
- Industrial cleaning
- Spunlace
- Deburring

Identification code

see tables on the next page >>>

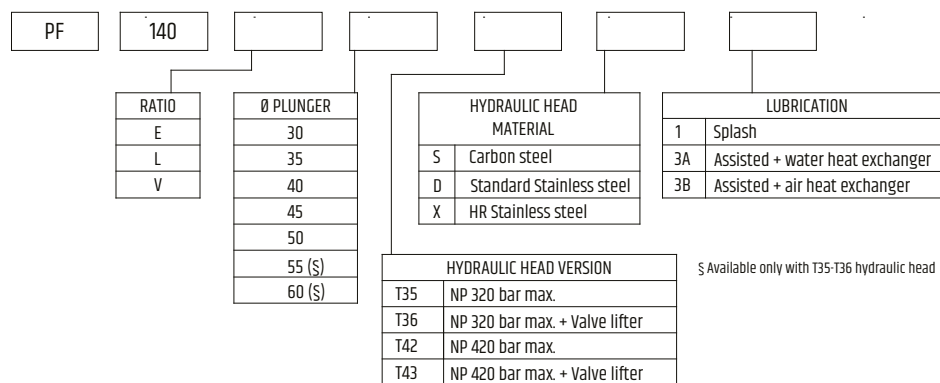

Dimensions

Dimensions are referred to hydraulic head T42
Weight: kg 360

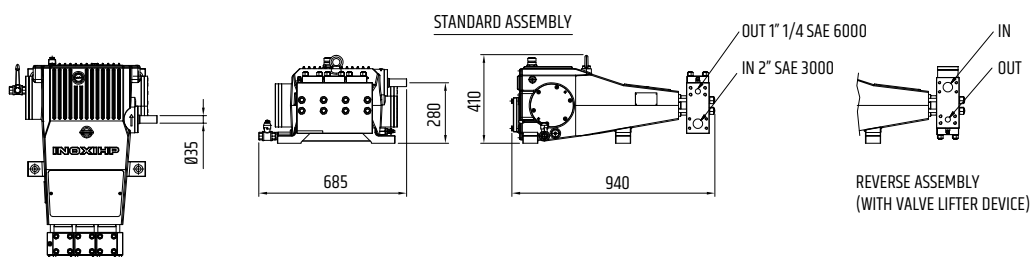

Pumping Group

PF 140

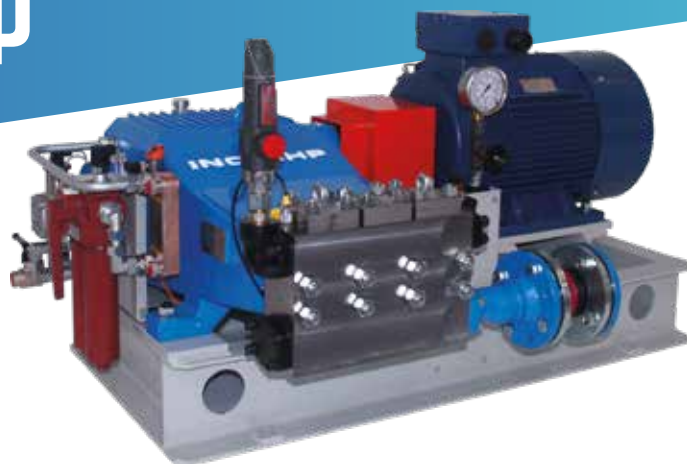

Composed of

- Pump PF 140 with splash or assisted lubrication complete with delivery pressure gauge and flanges
- Electric motor
- Safety valve
- Coupling with cover
- Frame
- Suction pressure switch

Options

- Manifold groups for suction/delivery
- Junction box
- Suction filters simplex or duplex with/without clogging detection sensor
- Valve lifter controlled by means of pneumatic solenoid
- HP check valve
- Low and high pressure switches
- Simplex or duplex suction filter

Dimensions

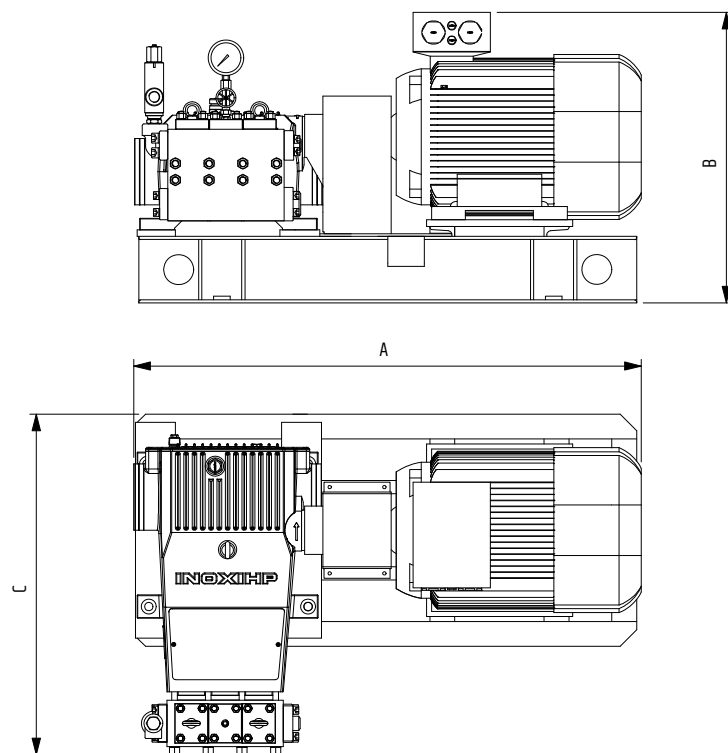

POWER (kW)	DIMENSIONS(mm)			WEIGHT (kg)
	A	B	C	
37	1505	805	1030	887
45	1530	805	1030	922
55	1605	875	1030	981
75	1700	935	1030	1110



These pump and pumping group model are EAC certified



INOXIHP S.r.l.

IT - 20834 Nova Milanese (MB) - Via Garibaldi, 89 - Tel: +39 0362 190111
Fax: +39 0362 1901008 - E-mail: inoxihp@inoxihp.com - inoxihp.com

INOXIHP
ABOUT USING WATER